

# Nanoject II

## Digital Control Box

INSTRUCTION MANUAL • 3-000-029-D



MADE  IN USA

LABORATORY EQUIPMENT  
E21997

## Rules for Safe Operation

- For indoor use only.
- Never operate unit in an explosive atmosphere.
- Do not operate unit with a damaged cord.
- Use power source only in a standard electrical outlet.
- Do not handle power source with wet hands.
- Do not put unit or power source in water or other liquid.
- When servicing, use only identical Drummond replacement parts.
- Save these instructions.

**If the equipment is used in a manner not specified by the manufacturer, the protection provided by the equipment may be impaired. Always use the power source that is supplied with the unit.**

### Connections to Power Source:

Check the power source to see that the line voltage corresponds to the voltage indicated on the mains adapter.

 If the mains adapter source and the line voltage are not compatible, the electrical components of the Nanoject II may be damaged or destroyed.

 Before each use, confirm that the mains adapter cable is not damaged, worn or severely buckled and there are no breaks in the insulating surface. If any damage is noted, do not use the Nanoject II until the damaged main is replaced.

**Connecting to power outlet:** The control box has a power source transformer attached to the box. Plug this into your outlet using the correct adapter supplied. There is an “on/off” switch on the side of the control box which turns on the control box once the injector head is attached. To turn off, use the switch to turn off. If you want to disconnect the power from the unit, merely unplug the transformer from the wall outlet.

**Power/Current Rating:** AC 100~V, 50-60 Hz, 38VA DC 12V 2A

Input: 100-240~V, 50-60 Hz, 0.6A

Output: 12V 2A

## Specifications for Usage

**This unit is intended to be used to inject nanoliter quantities of sample.**

**This equipment is for indoor use only.**

Temperature Range 10°C–35°C, Maximum Humidity 60%

**FAILURE TO USE THE EQUIPMENT IN ACCORDANCE WITH INSTRUCTIONS OR MODIFYING THE EQUIPMENT WILL VOID WARRANTIES.**

**CAUTION:** CAREFULLY READ THROUGH THIS ENTIRE MANUAL BEFORE USING YOUR NANOJECT II. PAY CLOSE ATTENTION TO THE RULES FOR SAFE OPERATION WARNINGS AND CAUTIONS.

# Introduction

Thank you for purchasing the Nanoject II Control Box by Drummond Scientific Company. This device can be used immediately after purchase. A summary of how to operate the device is provided in this quick instruction manual.

## Accessories available for purchase:

Replacement Glass 3.5" (vial of 100)	3-000-203-G/X
Replacement Glass 7" (vial of 100)	3-000-203-G/XL
O-ring Kit with Collet	3-000-002-KN
Wire Plunger (replacement)	3-000-000-203-X
30G/2" Needle	3-000-027
Footswitch (remote capability for fill, empty and inject functions)	3-000-032
Micromanipulator, MM33 (right hand)	3-000-024-R
(left hand)	3-000-024-L
Support Base	3-000-025-SB
Magnetic Base	3-000-025-MB
Universal Adapter	3-000-024-A

# Technical Specifications

Part Number	3-000-029-D
Power Source	100/240 volt, 50/60 Hz
Total Sample Volume	4.2 nL
Fill Volume Speed	23 nL or 46 nL/sec
Empty Volume Speed	92 nL/sec (only)
Injection Rate	23 nL or 46 nL/sec
Volume Range	2.3 nL - 69.0 nL
Plunger Travel	27 mm
Glass Micropipette Dimensions	OD 0.045" (1.14 mm) ID 0.021" (0.53 mm)

## Control Box Dimensions

Weight:	0.43 kg
Length:	14 cm
Width:	13.5 cm
Thickness:	4 cm



# Quick Start Guide

- 1) Plug the injector cable into the “HEAD” port on the right side of the control box.
- 2) If using the footswitch, insert the footswitch cable into the “FOOTSWITCH” port on the right hand side of the control box.
- 3) Plug the control box into a standard electrical outlet using the appropriate adapter head on the power supply.
- 4) Turn on unit with the on/off switch located on the left hand side of the control box. Initially the Drummond logo will be displayed on the screen followed shortly by the Operational Mode screen.

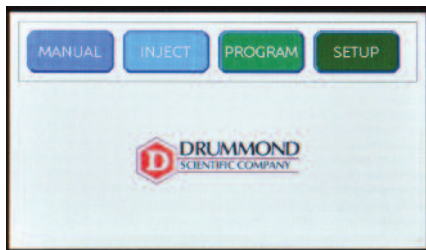

## 5) Micropipette Pulling and Backfilling

The Nanoject II requires the use of pulled micropipettes from the glass provided. Ideally, the tip size should be 10-30 microns in size. The capillary glass provided is produced from N-51-A material and has a softening point of 780°C. Many researchers pull the tips and then break them off with forceps. This enables piercing the cell membrane much easier with no skipping. Once the tips are pulled, they must be “backfilled” with oil (or other non-compressible fluid) before attachment to the injector. Silicone or mineral oil is frequently used. Backfilling is facilitated by using the 30 gauge x 2” needle and a syringe. Disposable spinal needles are also frequently used.

**NOTE: THE NANOJECT II WILL NOT OPERATE PROPERLY WITHOUT BACKFILLING THE MICROPIPETTE.**

## 6) Securing the Micropipette to the Injector Standard Collet/O-ring (Fig. 1)

Once the micropipette is backfilled, loosen the collet. The pointed wire plunger should be positioned so you can just see the tip flush with the end of the collet (slightly recessed is also acceptable). This is referred to as the “Home” position. Push the micropipette onto the wire plunger and as you push the tip on, feel it go through the large O-ring and seat in the white spacer. Once positioned, tighten the collet securely. Give the micropipette a pull to confirm it is securely mounted. See Fig. 1 for proper configuration of the O-rings and the white spacer. It is absolutely essential that these components are properly configured.

**NOTE: THE WHITE SPACER HAS ONE FLAT SIDE AND ONE SIDE WITH A RECESS MACHINED AROUND THE HOLE. THIS RECESS IS TO RECEIVE THE BACK END OF THE PIPETTE.**

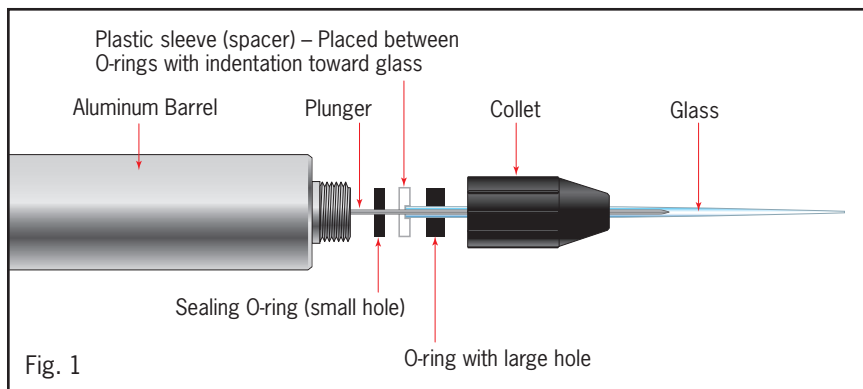

Fig. 1

## 7) Filling the Micropipette

First, select your fill speed by pressing the **[SETUP]** icon and choosing **23** or **46 nL/sec**.

**(NOTE: EMPLY SPEED IS PRESET TO 92 nL/SEC ONLY)**

Return to Main Menu by pressing the **[EXIT]** icon.

Then enter manual mode by pressing the **[MANUAL]** icon.

Once the micropipette is secured to the collet, press the **[EMPTY]** icon. This will drive the wire plunger out forcing oil to the tip of the pipette and any excess oil will be expelled. Extend the plunger until an audible beep is heard. The plunger is now fully extended (approx. 27 mm from the end of the collet).

Now place the tip of the pipette into your sample and press the **[FILL]** icon. The plunger will retract drawing with it the sample. The micropipette when fully filled, will contain approximately 4.2  $\mu\text{l}$  of sample. At any time you can stop filling by pressing the red **[STOP]** icon. Continued filling can be accomplished by pressing the **[FILL]** icon again. The plunger is fully retracted to its preset "home" position when you hear an audible beep. Viscous samples may require you to fill in small steps allowing the sample to equilibrate in the tip before continued filling. Do not allow air bubbles to form in the micropipette. These bubbles can cause inaccurate injection volumes.

NOTE: The plunger will continue to extend or retract until you press **[STOP]**, or fully extended or retracted position is reached.

## 8) Injecting Sample

To inject the sample, return to the Main Menu by pressing the **[EXIT]** icon. Press the **[SETUP]** icon then choose your **Speed (nL/sec)**, either 23 or 46 nL/sec. Then press the **[EXIT]** icon. Select inject mode by pressing the **[INJECT]** icon. Set the desired injection "Volume (nL)" from the displayed volumes. Press the **[INJECT]** icon to inject your sample.

NOTE: Multiple injections can be performed by simply pressing the **[INJECT]** icon again and again.

# Operational Modes

## [ MANUAL ] Mode

This mode will enable the user to manually fill and empty the micropipet. Pressing the [FILL] icon will retract the wire plunger, while pressing the [EMPTY] icon will cause the wire plunger to extend.

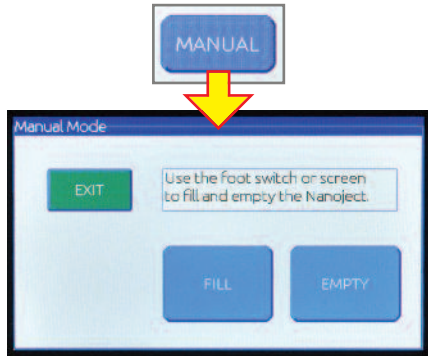

If the [FILL] or [EMPTY] icon has been pressed and you desire to stop the action, simply press the same icon position (now labeled [STOP]) a second time.

**Note:** [EXIT] icon is disabled while the wire plunger is in motion.

**Note:** The speed of the fill can be regulated in the [SETUP] mode and is independent of the injection rate. [EMPTY] has only one speed (92 nL per second).

Press the [EXIT] icon to exit back to the operational mode screen.

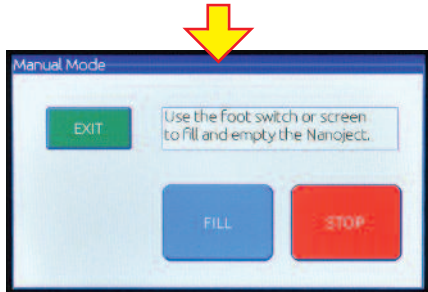

## [ INJECT ] Mode

This mode is used to do single manual injections. It enables the user to program an injection volume from the displayed volumes. Press the [INJECT] icon to inject the desired volume at the rate selected.

**Note:** Multiple injections can be performed by simply pressing the [INJECT] icon again and again. The injection rate is independent of the fill rate as programmed in the [SETUP] mode.

Press the [EXIT] icon to exit back to the operational mode screen.

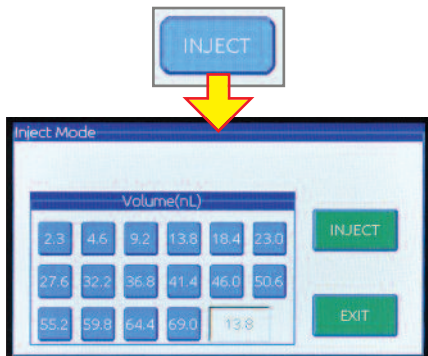

**PROGRAM**

**[ PROGRAM ] Mode**

This mode enables the user to program multiple injection cycle recipes. To program a new recipe, press the **[NEW]** icon. A screen displaying the sample injection volume (nL) and an injection rate (nL/sec) will appear. As before, adjust these individual values by using the respective displayed volumes and rates.

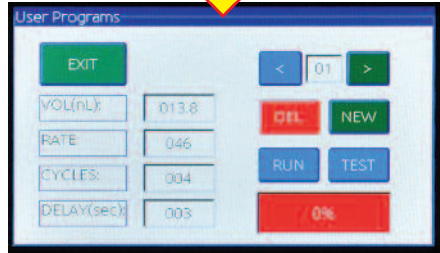

Pressing the **[NEXT]** icon brings up a screen displaying the number of injection cycles. Again, use the **[+]** and **[-]** icons to select the value desired.

Pressing the **[BACK]** icon always returns you to the previously displayed screen.

Pressing the **[NEXT]** icon once again brings up the screen displaying the interval (secs) between injection cycles. Use the **[+]** and **[-]** icons to set the desired time.

Pressing the **[SAVE]** icon allows you to view the entire program recipe values in the following format:

**VOL (nL)** . . . . volume of injection

**RATE (nL)** . . . . rate of injection

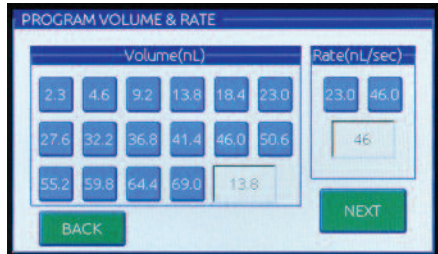

**CYCLES** . . . . number of cycles this volume will be injected

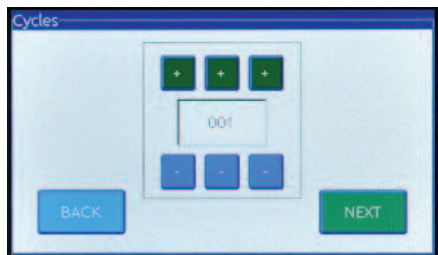

**DELAY (SEC)** . . time interval between each injection

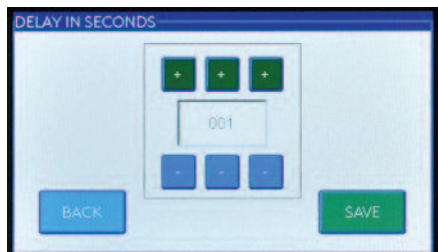

---

**Note:** The program recipes are automatically saved and labelled in sequential order. You can step through the stored recipes by pressing the [**<**] and [**>**] icons. Should you desire to delete a recipe, simply press the [**DEL**] icon, and the displayed recipe will be deleted.

Pressing the [**RUN**] icon will initiate the currently displayed program recipe.

After pressing the [**RUN**] icon, a [**PAUSE**] icon appears and enables the user to interrupt the program at any time, and then resume the program where it was interrupted by pressing the [**RUN**] icon again.

To initiate a single cycle of the displayed recipe, simply press the [**TEST**] icon once.



Below the [**RUN**] icon is a box displaying the number of injection cycles remaining in the entire program recipe. It will count down toward (0) as the multiple injection cycle progresses. Below this "counter" box is a display of the percentage of the program recipe remaining. It will increase to 100% as the multiple injection cycle progresses.

Press the [**EXIT**] icon to exit back to the operational mode screen.

## [**SETUP**] Mode

This mode will enable the user to program and store the manual fill and injection rates respectively to either 23 nL or 46 nL.



**Note:** When retracting the plunger to the "Home" position, press the STOP button when the plunger tip is aligned with the end of the collet; **plunger will not stop automatically. (Damage to the motor may occur if plunger is not stopped at proper "Home" position).**

Press the [**HOME**] icon to manually retract the plunger to the "Home" position.

Press the [**EXIT**] icon to exit back to the operational mode screen.



# Footswitch Operation

## [ **MANUAL** ] Mode

In this mode, the micropipette is manually filled or emptied.

Touch the [**MANUAL**] icon to go to the MANUAL MODE screen in the diagram below.

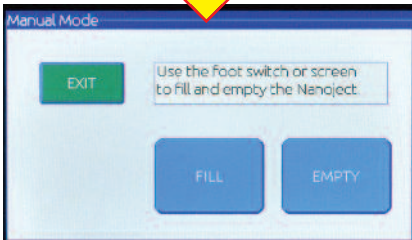

## EMPTY Function

When you touch this icon and the icon changes to a red **[STOP]** icon, the motor continues to empty the micropipette.

When the plunger has extended completely (approximately 23 mm from the end of the collet), there will be a beeping sound and the screen will return to the **[EMPTY]** icon at the same time.

To stop it in the middle, push **[STOP]**.

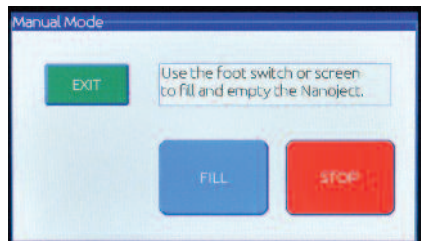

The one-touch functions such as **[EMPTY]** and **[FILL]** cannot be done with the footswitch. The same phenomenon will occur if you continue to push the pedals for functions such as **[EMPTY]** and **[FILL]**. If you ease the pressure off the pedal, the motor will stop.

# Footswitch Operation

## [INJECT] Mode

On the Operation screen, select **[INJECT]** mode.

Enter the manual **[INJECT]** conditions.

[VOLUME (NL)] = Displayed in ranges within 2.3 nL to 69 nL.

[RATE (NL/SEC)] = Injection speed of 23 nL or 46 nL.

When setup is finished, the green **[INJECT]** icon starts injection.

One push (push all the way)=one shot, then it will change to a yellowish green **[INJECT]** icon, and there will be a beeping sound when it is finished.

**[EXIT]** Goes back to the operation screen.

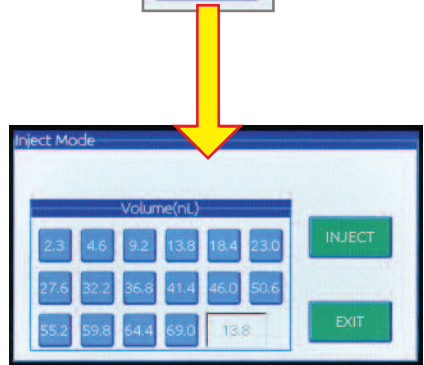
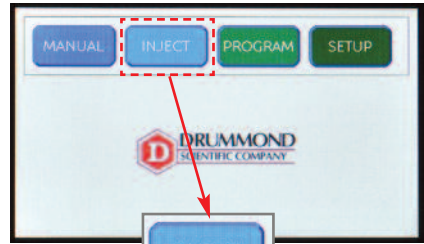

When using **[INJECT]** with the footswitch, please continue to push the pedal until you hear the beeping sound.

The motor is still in operation until you hear the beeping sound.

If you ease the pressure off the pedal before you hear the beeping sound, the motor will stop and the set volume will not be injected.

In this mode, the **[FILL]** and **[EMPTY]** pedals are disabled.



**Questions:** Please contact Drummond at **800-523-7480**.



**DRUMMOND**  
**SCIENTIFIC COMPANY**

500 Parkway, Box 700  
Broomall, PA 19008  
800/523-7480 · FAX: 610/353-6204  
Website: [www.drummondsci.com](http://www.drummondsci.com)

For Technical Assistance, call  
**1-800-523-7480** or e-mail  
**[info@drummondsci.com](mailto:info@drummondsci.com)**